

N:\cadd\CIT\STANDARDS\STANDARD DRAWING DETAILS\2007--Concrete Details REV 5-10-07.dwg, C-02 (REV 3-2007), 5/29/2007 3:14:23 PM

SEE PROJECT PLANS FOR PAVEMENT AND BASE COURSE TYPE AND THICKNESSES

FINISHED BITUMINOUS PAVEMENT 1/4" TO 1/2" ABOVE EDGE OF GUTTER

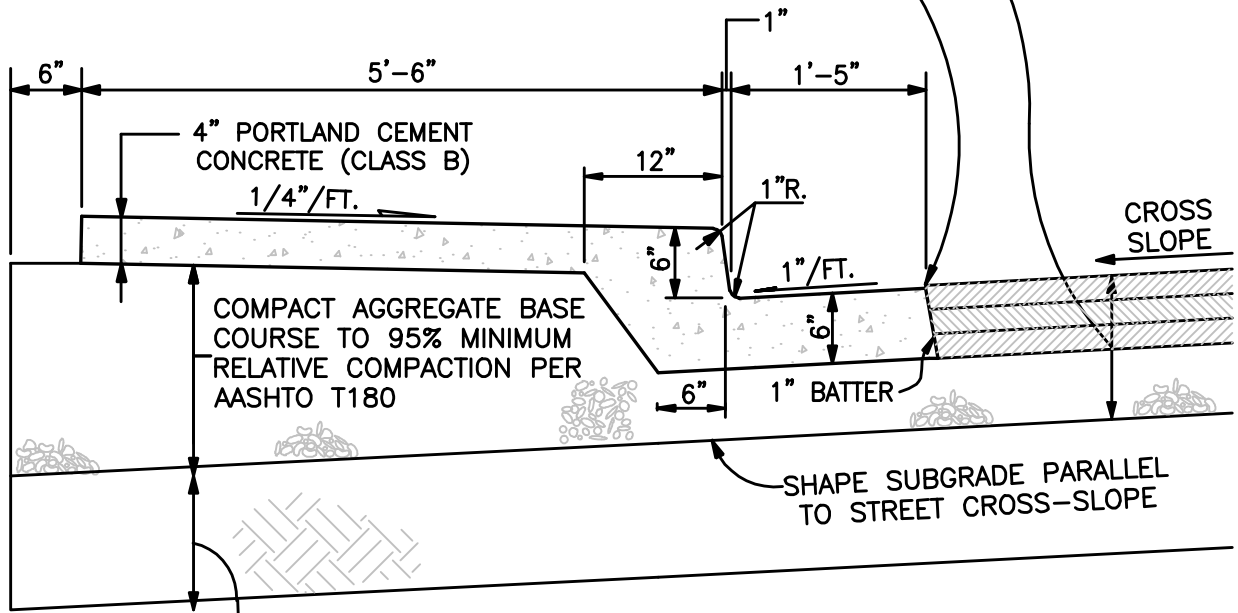

12" MIN. SUBGRADE RECONDITIONING - SHALL INCLUDE REMOVAL, REPLACEMENT AND COMPACT SOIL TO 95% MINIMUM RELATIVE COMPACTION PER AASHTO T-99.

STANDARD FOR MINOR ARTERIAL, COMMERCIAL AND COLLECTOR STREET CLASSIFICATIONS.

SEE DETAILS ON PAGE C-25 FOR CONSTRUCTION OF SIDEWALK ADJACENT TO EXISTING CURB AND GUTTER

MONOLITHIC VERTICAL CURB, GUTTER AND SIDEWALK

DEPARTMENT OF PUBLIC WORKS AND PLANNING
ENGINEERING DIVISION
CITY OF GRAND JUNCTION, COLORADO

STANDARD CONCRETE
DETAIL

APPROVED: DN
DATE: FEB. 2006
DRAWN: CM

PAGE
C-02