

MAXIMUM SPACING OF EXPANSION JOINTS IN ALL CURB, GUTTER AND SIDEWALK SHALL BE 250'.

SEE SECTION 705.01 OF THE STANDARD SPECS. FOR ROAD AND BRIDGE CONSTRUCTION FOR APPROVED JOINT SEALANTS. SEALANT SHALL BE SAME COLOR AS CONCRETE

W = 3/4" FOR EXPANSION JOINTS  
1/2" FOR ISOLATION JOINTS

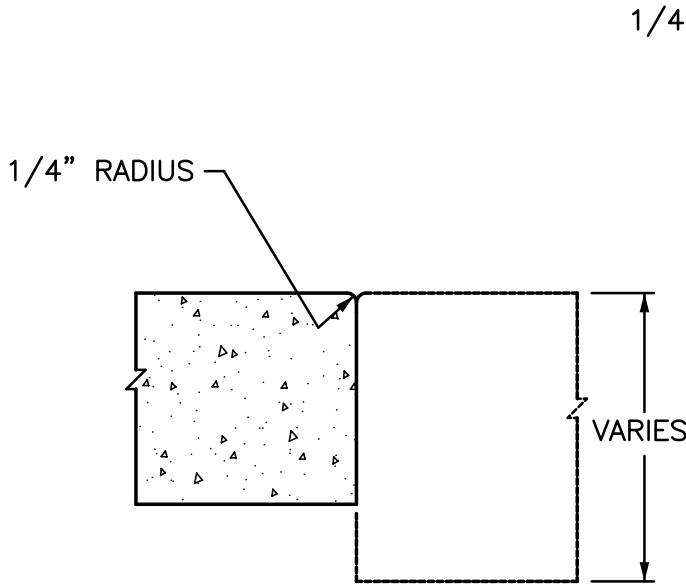

UNDOWELED CONSTRUCTION OR BUTT JOINT

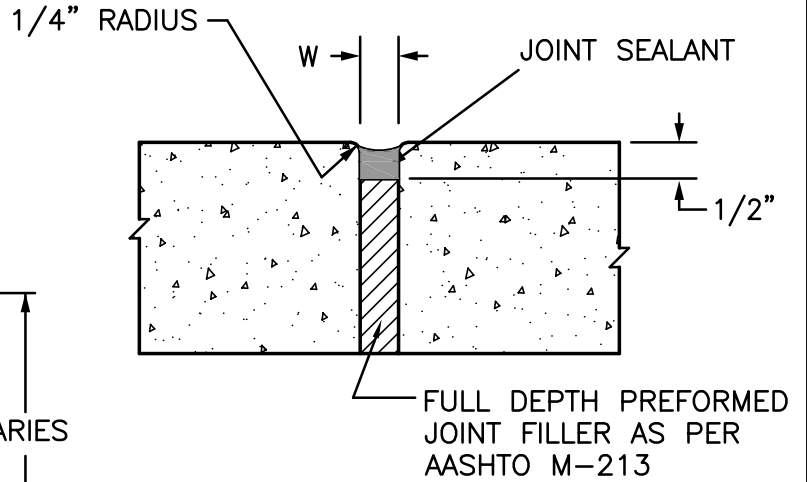

UNDOWELED EXPANSION OR ISOLATION JOINT

CONTRACTION JOINT SPACING

- 5' MINIMUM
- 10' STANDARD
- 10' MAXIMUM

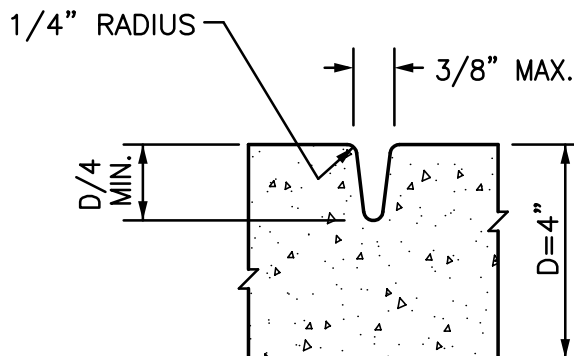

TOOLED JOINT

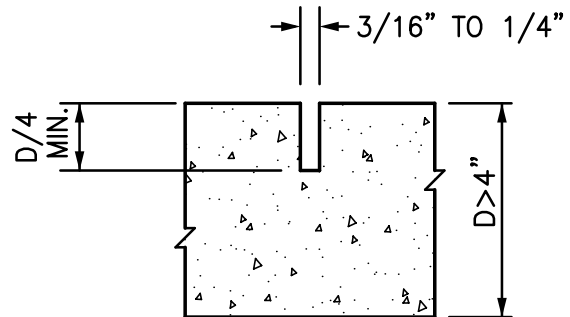

SAWED JOINT

TRANSVERSE CONTRACTION JOINTS

JOINT DETAILS FOR CURB, GUTTER, SIDEWALK AND DRIVEWAY APPROACHES